

HIGH PERFORMANCE Thermal Management

Q-CHILL Internal Fin Technology

001-MXQ-01 Liquid Cooled Coldplate

The 001-MXQ-01 is a liquid cooled coldplate specifically designed for challenging power density applications requiring a compact and light-weight design. The advanced design of the 001-MXQ-01 allows for efficient heat transfer between the coldplate contact area and the power module base plate.

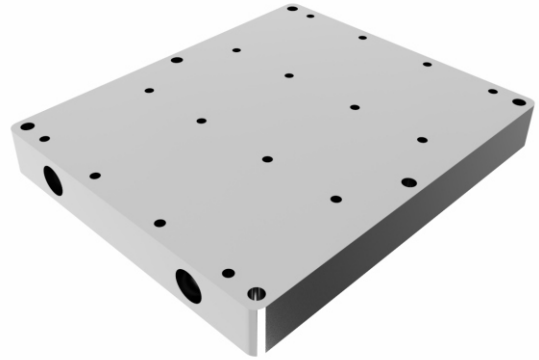

Applications

- Electric Vehicle Motor Drives
- Wind Turbines
- Solar Inverters
- Industrial Motor Controls
- Power Converters
- Induction Heaters
- Rail Traction Systems
- Auxilliary Vehicle Systems
- High Performance Motor Sport

Compatible Power Module Packages

- SEMIKRON SKiM® 63

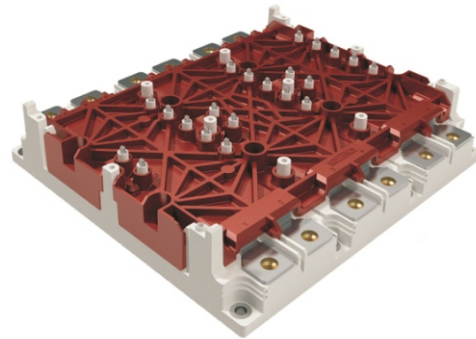

Features

- 3000 Watt heat rejection @ 8 LPM with a 25° C temperature rise from the fluid inlet to the maximum coldplate temperature
- Patent pending Q-CHILL internal fin technology provides for a more uniform top coldplate surface temperature
- Low pressure drop for reduced system cost (1.1 PSI @ 8 LPM)
- Low cost proven aluminum solution with performance comparable to copper based solutions
- Power Compact and light (1.0 kg)
- Compatible with industry accepted coolants
- Metallurgical seal for robustness and a high pressure rating

Corporate Headquarters

MaxQ Technology, LLC
8270 S. Kyrene Road, Suite 108
Tempe, AZ 85284
United States
(877) 804-0284

For Sales Information

sales@maxq.com
(877) 804-0284 Ext. 103

For Technical Support

tech@maxq.com
(877) 804-0284 Ext. 102

Please visit our website at www.maxq.com

PERFORMANCE CURVES

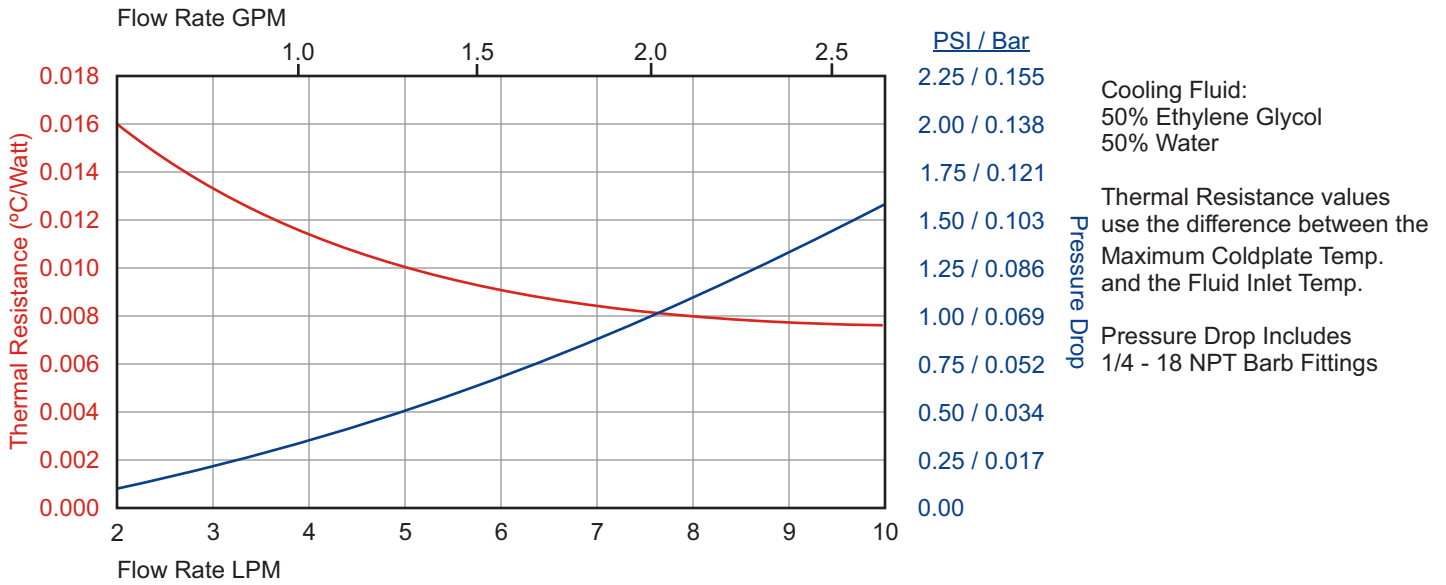

MECHANICAL OUTLINE

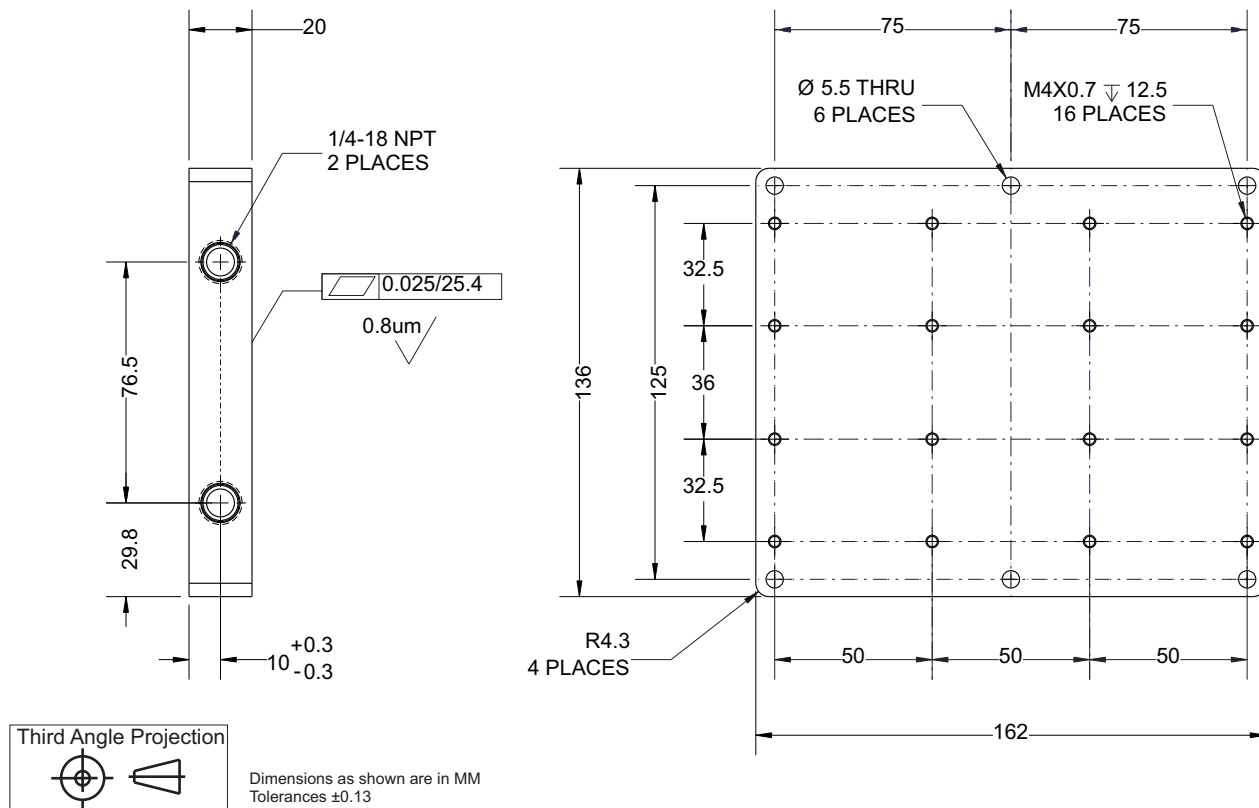

Corporate Headquarters
MaxQ Technology, LLC
8270 S. Kyrene Road, Suite 108
Tempe, AZ 85284
United States
(877) 804-0284

For Sales Information
sales@maxq.com
(877) 804-0284 Ext. 103

For Technical Support
tech@maxq.com
(877) 804-0284 Ext. 102

Please visit our website at www.maxq.com